

(No Model.)

N. D. CHARD.  
TOOL TURRET.

No. 567,080.

Patented Sept. 1, 1896.

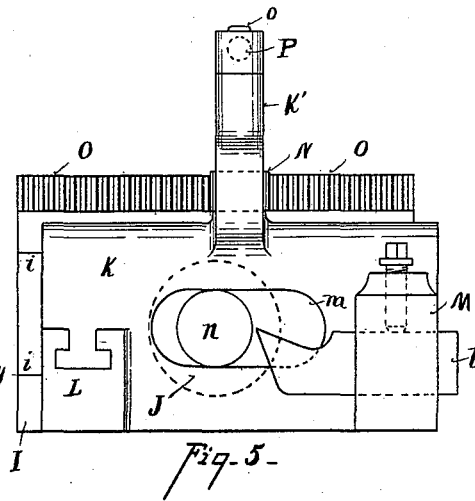
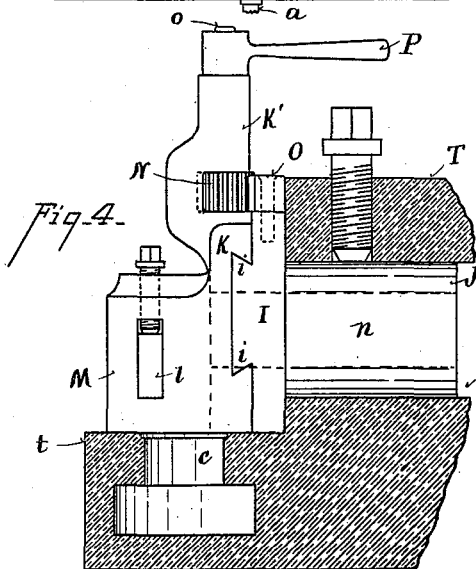
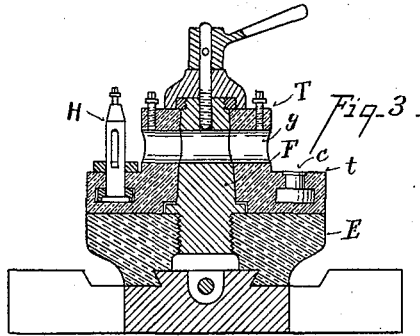
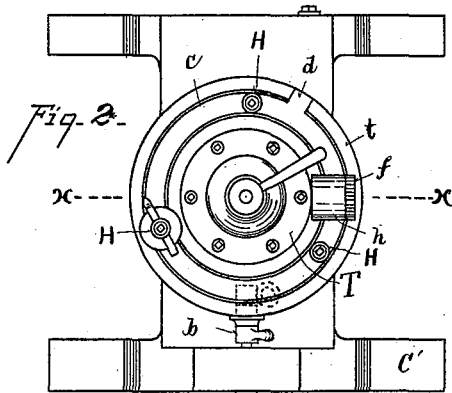
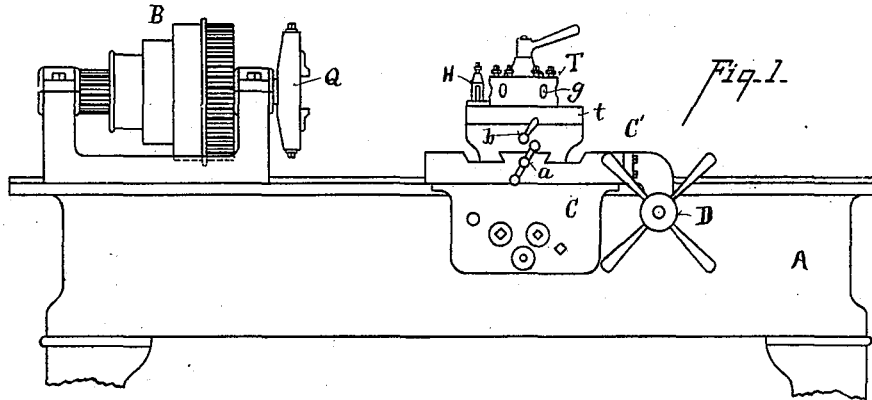

Witnesses  
 C. W. Miles  
 Oliver B. Kaiser

Inventor  
 Nicholas D. Chard  
 By Wood & Bond  
 Attorneys

# UNITED STATES PATENT OFFICE.

NICHOLAS D. CHARD, OF CINCINNATI, OHIO.

## TOOL-TURRET.

SPECIFICATION forming part of Letters Patent No. 567,080, dated September 1, 1896.

Application filed January 23, 1895. Serial No. 535,929. (No model.)

To all whom it may concern:

Be it known that I, NICHOLAS D. CHARD, residing at Cincinnati, in the county of Hamilton and State of Ohio, have invented certain new and useful Improvements in Tool-Turrets, of which the following is a specification.

My invention relates to an improvement for holding tools adapted to be used with lathes or other similar machines.

One of the objects of my invention is to provide means for holding tools so that two or more tools may be supported in and operated by the turret at one and the same time.

Another object of my invention is to obviate the necessity of using box-tools.

Another object of my invention is to provide an improved tool-holder for supporting a plurality of tools.

Another object of my invention is to provide an improved cutting-off device and forming-rest adapted to be used in a turret.

The features of my invention will be more fully set forth in the description of the accompanying drawings, making a part of this specification, in which—

Figure 1 is a side elevation of a lathe with my improvement attached in position for use. Fig. 2 is a top plan view of the turret-carrier. Fig. 3 is a section on line *x x*, Fig. 2. Fig. 4 is an enlarged side elevation, partly in section, of the cutting-off device attached to my improved turret. Fig. 5 is a front elevation of the cutting-off device.

In order to illustrate one of the uses of my improved turret, I have shown it as mounted on an ordinary lathe.

A represents the bed of the lathe; B, the head-stock, showing the gears and cone-pulleys.

C C' represent the turret-carrier.

D represents the hand-wheel for feeding the tool-carrier forward and backward.

*a* represents the handle of a screw-rod for moving the turret transversely.

*b* represents a locking-bar for holding the turret to any rotary adjustment.

T represents my improved turret, which is mounted upon an ordinary turret-base E and supported by a spindle F, which parts are of ordinary construction. My turret consists of a terrace or terraced base *t*, having an an-

nulus *c*, preferably of T form. *d* represents a slot cut through the flange *e* of the periphery of said terrace or terraced base, which is a convenient means for inserting the tool-posts H. Any desired number of tool-posts H may be placed in the annulus *c*.

*g* represents openings pierced through the cylindrical portion of the turret, which corresponds to the openings in the ordinary turrets.

By the construction of my turret having a vertical cylinder provided with horizontal terrace the latter may be employed to hold tool-stocks without employing box-tools. The most convenient form of holding said tool-

stocks is by means of a T-slot, but I do not wish to limit my invention to this, as the terrace or terraced base itself may be employed in various ways for forming the vertical support for tool-stocks. By the use of the vertical tool post or stock the tool is rigidly held in position and the trembling of the tool which occurs in the use of the box-tools is avoided and two tools opposite to each other supported on the base may be employed at the same time.

*f* represents a die supported in the turret by a stock having a tenon fitting in the horizontal opening *g*, preferably with the boss of the stock resting on the terrace or terraced base *t*. Another convenient means of supporting tools on the base of my turret is shown in Figs. 4 and 5.

I represents the head-block of the tool, provided with a tenon J, fitting in one of the horizontal openings *g* of the turret. Said head-block is provided with a dovetailed tongue *i*. K represents a slide the inner face of which is provided with a groove, which fits and slides upon the dovetail *i*. Said slide is provided with one or more T-headed lugs L, upon which are supported tool-stocks M.

*m* represents a slot pierced in the face of the slide K.

*n* represents an opening through the tenon J of the head-block I to allow the work operated on by the tool to enter. Slide K is provided with a stem K', projecting upward above the slide. In said stem is mounted a pinion N, engaging with the teeth of rack-bar O. Said pinion is mounted upon a spindle *o*, which journals in the stem K' and is

turned by the handle P to rotate the pinion N and move the slide laterally across the axis of the work, which enters the opening *n*.

Mode of operation: Suppose the lathe to be employed for forming screws or bolts. One of the tool-posts H is brought into position, as shown in Fig. 1, for turning down the work to the required diameter. The die *f* is brought into position to cut a thread. When this is accomplished, the direction of the head Q is reversed, the die *f* released, and the lathe may then be turned so as to bring the cutting-off tool L into position to sever the bolt. This will illustrate one variety of work, and persons of skill in the art will readily understand how to use all the various kinds of tools that are required for such work.

It will be observed that the spindle F is constructed with an annular opening through it to form a way, in connection with the openings G opposite thereof, in a plane parallel with the axis of the driving-shaft, and this is the preferred form of construction, as it provides a suitable journal-support for the turret and a workway for the stock to pass through freely.

The turret is of a new form and construction, and it might be termed a "terraced" turret, having one or more terraces, as desired, with a toolway formed on the terrace or terraces.

I claim—

1. A terraced tool-turret for a lathe, having one or more toolways formed on the terraces, and openings G in its vertical face, substantially as specified.

2. In a lathe, a terraced turret having openings G in the vertical face, in combination

with a spindle F having an opening through it with which the openings G of the turret register, and a toolway formed on the terrace, substantially as specified.

3. In a lathe, a terraced turret provided with an annulus *c* formed in the terrace and adapted to support a series of tool-holders H, and a series of openings *g* pierced in the vertical face of the turret, and forming a workway, substantially as herein specified.

4. In combination with a terraced turret, the head-block I supported on the face of the terrace, a slide M connected to said head-block by ways, mechanism for moving said slide longitudinally across the face of the terrace, and means for supporting a tool in said slide, substantially as specified.

5. In a lathe, the combination with a terraced turret, of a tool-holder connected to the vertical head-block I supported upon the terrace of the turret against the vertical face thereof, the slide K having the tool-holder support *l*, the tenon J seated in the opening *g* of the turret, and the rack-and-pinion mechanism for moving the slide laterally on its head-block, substantially as specified.

6. In combination with the terraced turret of a lathe, the slide K supported upon the head-block I and upon the terrace of the turret and provided with a slot adapted to support one or more tool-stocks, and mechanism for moving said slide laterally upon the way of the head-block, substantially as specified.

In testimony whereof I have hereunto set my hand.

NICHOLAS D. CHARD.

Witnesses:

WILL R. WOOD,  
OLIVER B. KAISER.